

M20CRW3 - 20 kW
AC Output¹

20 kW	60 Hz, 1800 RPM
Amperage	120-240V / 83 A, 120V / 166 A
Phase/power factor	Std: 1/1.0 (Opt. 3/0.8)

Voltage regulation	±1%
--------------------	-----

Lugger L844L2 Engine

Type	Vertical inline 4 cylinder diesel
Displacement	135 in ³ (2.2 ltr)
Bore/Stroke	3.30/3.90 in (84/100 mm)
HP @ RPM	32/1800

Approx. fuel use

1800 RPM @ full load ²	1.7 gph (6.5 lph)
1800 RPM @ half load ²	1.0 gph (3.9 lph)

Installation Data & Weight

Wet exhaust elbow	2 inch OD
Dry exhaust outlet	1 1/2 inch NPT
HE raw water inlet	3/4 inch (19 mm) OD
KC coolant inlet / outlet	1 1/4 inch OD
Keel Cooler	6 ft turbo tube /12 ft plain tube
Fuel inlet	5/16 inch JIC male
Fuel return	1/4 inch JIC male

Approximate dry weight	820 lbs (372 kg)
------------------------	------------------

1. Based on SAE J1995 and ISO 3046.
2. Actual fuel consumption will vary depending on operating conditions

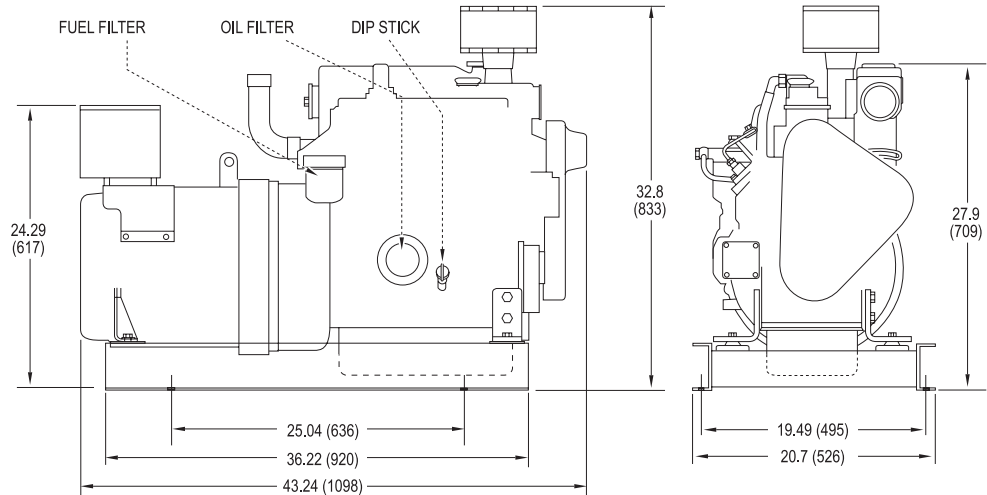
Dimensional Drawing

M20CRW3 Overall Dimensions L x W x H: 43.2 x 20.7 x 32.8 inch (1098 x 526 x 833 mm)

Dimensions given in inches (mm). Dimensions subject to change without notice.
Contact dealer or visit www.northern-lights.com for most current installation drawings.

M20CRW3 Features and Benefits
Engine Block

- Four cycle, 4 cylinder, liquid cooled, naturally aspirated, overhead valve diesel.
- Swirl combustion chambers improve fuel efficiency and reduce smoke.
- Glow plugs for quick cold starting.

Cooling System

- Jacket-water cooling system in heat exchanger or keel cooled configuration.
- One-piece heat exchanger housing, expansion tank and liquid cooled exhaust manifold. Fewer troublesome hoses and gaskets. Cast iron to resist corrosion and electrolysis.
- Keel cooling configuration is standard
- Heat exchanger cooling is optional. Cupro-nickel, tube-type heat exchanger element can be removed for easy cleaning. Easily accessible, rubber impeller seawater pump of bronze and stainless steel is gear driven; no pump drive belts to fail. Cast-iron wet exhaust elbow is included.

AC Generator

- Northern Lights, direct coupled, brushless AC generator is maintenance free. 12 lead design is reconnectable for 1 or 3 phase, 60 Hz output. Conservative heat rise rating: 95°C/50°C ambient.
- Automatic Voltage Regulator (AVR) is powered by dedicated AC winding for true 300% short circuit capability. Quick ±1% RMS no load to full load voltage regulation. AVR has circuit breaker protection.
- Generator features high quality Class "H" epoxy insulation, accessible diodes, over-sized bearing and junction box for wiring.

Intake and Exhaust

- Meets US EPA Tier III emission requirements for a cleaner environment.
- Disposable dry air cleaner.
- 1 1/2 inch NPT exhaust outlet.

Lubrication System

- Full flow, spin-on oil filter with bypass.
- 8.6 qt. (8.2 ltr) oil capacity for better lubrication. 200 hr oil change intervals.
- Oil drain for quick, clean oil changes.
- Closed crankcase vent system keeps oil vapor inside engine for clean engine room.

Fuel System

- Fuel system is self-venting.
- Injection pump with 5% mechanical governor for close AC frequency control.
- Pintle injectors with replaceable tips.
- Mechanical lift pump with hand primer. No electric pump to fail.
- Large spin-on fuel filter.
- Stop solenoid controls the fuel rack, not throttle, to eliminate speed variance and linkage problems.

DC Electrical System

- DC system uses reliable relays instead of unrepairable printed circuit board.
- 12 volt starter motor and battery charging alternator with regulator and belt guard.
- Standard panel: Remote mount S-3C has hour and volt meters, oil pressure and coolant temperature gauges, stop-start switch and preheat switch.
- 20 foot (6 m) plug-in panel harness lets you mount your panel anywhere on board. DC system is expandable to six panels up to 110 feet from the set.
- Low oil pressure and high coolant temperature shutdowns are standard.

Special Equipment

- Rigid welded steel base frame.
- Four platform mounts isolate vibration.
- Tough gray enamel paint for long life finish.
- Operator's and parts manuals standard.

www.northern-lights.com

Dealer

Northern Lights, Inc. • 4420 14th Ave. NW., • Seattle WA 98107
Tel: 206-789-3880 • 1-800-762-0165 • Fax: 206-782-5455
Information and dimensions subject to change without notice.
Northern Lights and Lugger are registered trademarks of Northern Lights, Inc.
© 2015 All rights reserved. Litho USA. S114 4/15